

Maintenance Procedures

Electrode Adjustment

Check the placement of the electrodes according to the illustration below. If adjustments are required, loosen the 1/4" screw. Make adjustments in the order listed below. Recheck, and if necessary, re-adjust until electrodes are in proper position.

- 1) From center of nozzle orifice to electrode - up 5/16"
- 2) Electrode Gap (distance between electrodes - 1/8"
- 3) Relationship of the end of the electrodes to the tip of the nozzle - 1/8" ahead
- 4) Relationship of the tip of the nozzle to the inside radius of the end cone -- Flush to 1/16" ahead - NEVER BEHIND

For

RA 350 ; RA 500

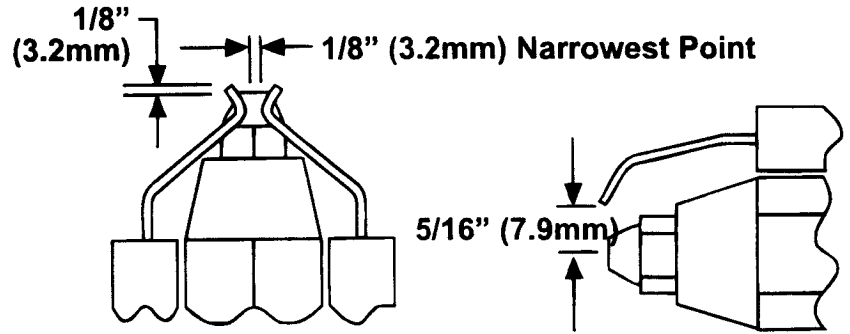

Electrode Adjustment

Check the placement of the electrodes according to the illustration below. If adjustments are required, loosen the 1/4" screw. Make adjustments in the order listed below. Recheck, and if necessary, re-adjust until electrodes are in proper position.

- 1) From center of nozzle orifice to electrode - up 3/8" (9.5mm)
- 2) Electrode Gap (distance between electrodes - 3/32" (2.4mm)
- 3) Relationship of the end of the electrodes to the tip of the nozzle - 1/16" (1.6mm) ahead
- 4) Relationship of the tip of the nozzle to the inside radius of the end cone -- Flush to 1/16" (1.6mm) ahead - NEVER BEHIND

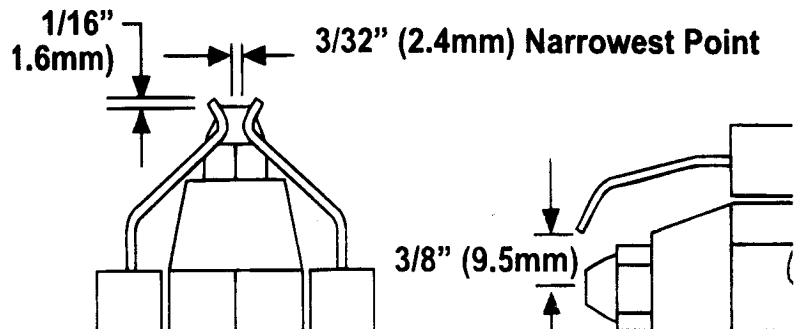

FOR RA 140 - RA 150 - RA 225
RA 235 - RA 250 - RA 325